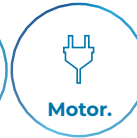

Table Standard

Motorised tilt table trolley

Up to 95" monitor.
Electrical motor for height adjustment and 90° manual tilt.
Creates an interactive table with the mounted display.

HMIFMIMI



Specifications

Floor stand with motorised height adjustment and 90° manual display tilt regulation

Ideal solution for touch displays in education, corporate, digital signage or event fields

Portable and easy to move between rooms

Max. height movement: 650 mm

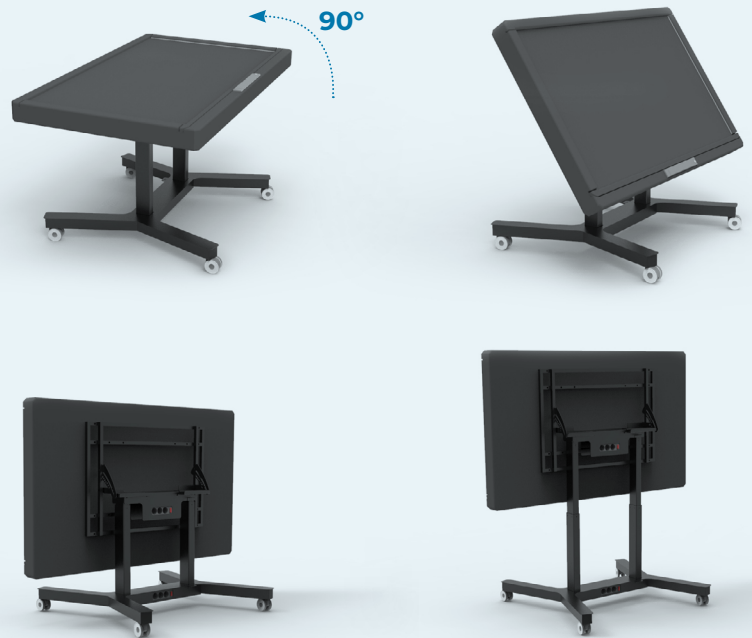

Display lock

Simple installation & operation

Wheel system with brakes

CE certified

Product Details

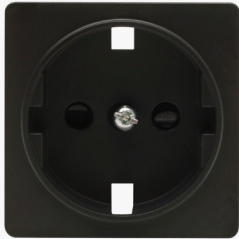

Built in power socket

Allowing an easy & comfortable powerment



Anti-Collision function (Optional)

Integrated sensor minimising the risk of collision with obstacles in the up & down direction.



Wireless control

Motor control via bluetooth with app.



Cable management

Optional energy chain to ensure the supply of energy while in constant motion.



Flexible solution

100 cm clearance between the wheels

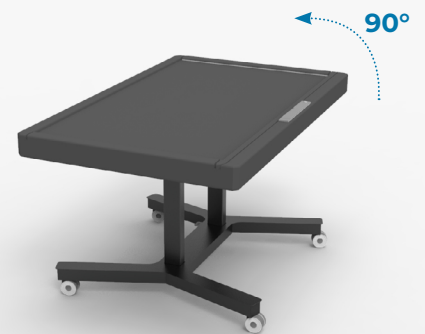

90° Regulation

90° manual display tilt regulation

Code HMIFMIMI		
WEIGHT & DIMENSIONS	Weight	50 kg
	Width	1050 mm
	Depth	850 mm
	Height	1350 mm
	Type of packaging	Carton
TECHNICAL DETAILS	Number of wheels	4
	Type of base	H-shaped
	Motorized	Yes
	Lockable wheels	Yes
ERGONOMICS	Height adjustment	Yes
	Rotating	No
	Tiltable	Yes
	Cable management	Yes
	Height adjustment range	0 - 650 mm
	Adjustable width	No
	Adjustable shelves	No
	Post-installation leveling roll	Yes
	Remotely controlled	Yes
	Telescopic	Yes
	USB Hub integrated	No
	Anti-collision	Optional
	Height adjustment type	Electric
	On/Off Switch	Yes

MOUNTING	Minimum screen size	32"
	Maximum weight (capacity)	100 kg
	Maximum screen size	95"
	Mounting type	Floor
	Minimum VESA mount	200 x 200 mm
	Maximum Vesa mount	900 x 600 mm
	Panel mounting interface	200 x 200,300 x 400,300 x 300,300 x 200,400 x 200,400 x 400,400 x 300,400 x 600,600 x 200,600 x 300,600 x 400,600 x 600,600 x 500,800 x 200,800 x 400,800 x 500,800 x 600,900 x 600
Minimum distance to floor	700 mm	
Maximum distance to floor	1350 mm	
DESIGN	Product colour	Black
	Orientation	Horizontal/Landscape
	Certification	CE
	Housing material	Steel
PACKAGING CONTENT	User manual	Yes
	Portable remote control	Yes
	Mounting kit	Yes
	Packaging content	Structure + floor base + display plate + installation guide + screws-bolts-nuts + castors
OTHER FEATURES		
Wheels included		
WARRANTY	5 years	

VESA Display Mounts

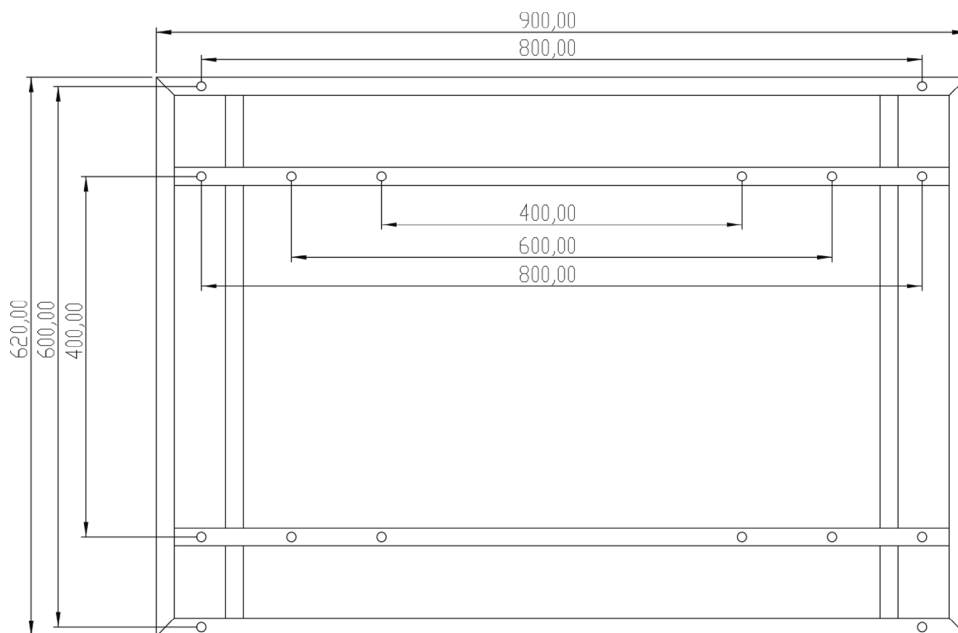

Display Heights

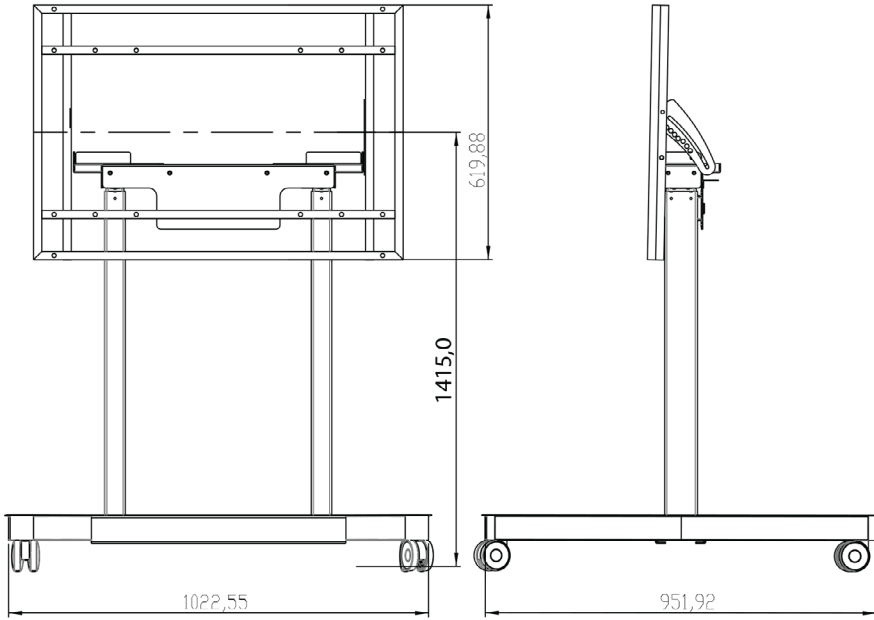

Top position / Trolley configuration: 1415 mm

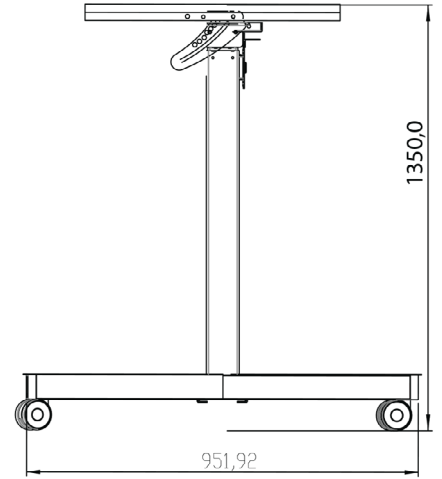

Top position / Table configuration: 1350 mm

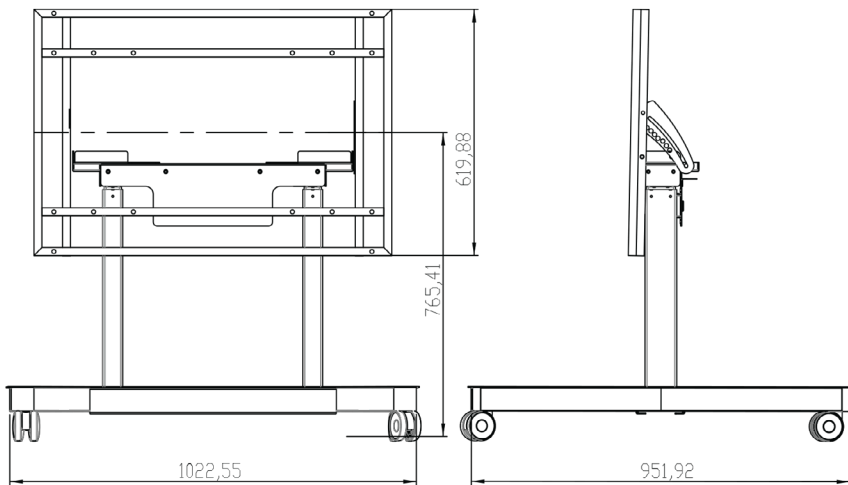

Bottom position / Trolley configuration: 765 mm

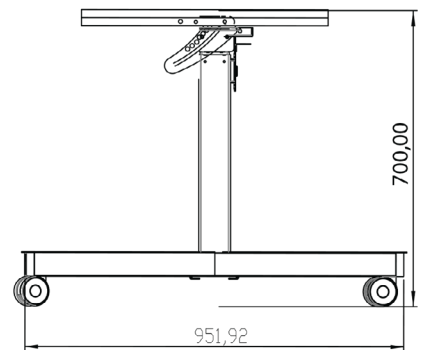

Bottom position / Table configuration: 700 mm

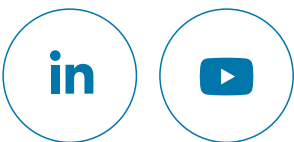

www.HELGI-europe.com

HELGI Europe
education@helgi-europe.com
business@helgi-europe.com

#080321HMIFMIMI_EN

Distributor